



®

CENTRIFUGAL UPBLAST ROOF EXHAUST FAN  
BELT DRIVE





RUB UPBLAST  
ROOF EXHAUST FAN

**Parameter**

Motor HP	Fan RPM	Static Pressure in Inches wg										
		0	0.125	0.25	0.375	0.5	0.75	1	1.25	1.5	1.75	
RUB-10BS-C												
1/4	590	CFM	1069	851								
		BHP	0.04	0.04								
		Sones	5.0	4.5								
	725	CFM	1313	1151	917							
		BHP	0.06	0.07	0.07							
		Sones	5.1	5.0	4.4							
	860	CFM	1558	1427	1264	1034						
		BHP	0.11	0.12	0.12	0.12						
		Sones	7.3	7.5	7.1	6.5						
	1105	CFM	2001	1906	1793	1667	1515	998				
		BHP	0.23	0.24	0.25	0.26	0.26	0.23				
		Sones	10.9	10.8	10.6	10.3	10.0	9.6				
1/3	1140	CFM	2065	1973	1864	1745	1605	1167				
		BHP	0.25	0.26	0.27	0.28	0.29	0.27				
		Sones	11.3	11.3	11	10.7	10.3	10				
	1210	CFM	2192	2106	2006	1896	1773	1443				
		BHP	0.3	0.31	0.32	0.33	0.34	0.34				
		Sones	12.2	12.2	11.7	11.6	11.2	10.9				
1/2	1390	CFM	2518	2445	2362	2271	2174	1949	1643			
		BHP	0.45	0.47	0.48	0.5	0.51	0.52	0.51			
		Sones	14.9	14.7	14.2	13.2	12.9	12.1	11.0			
3/4	1495	CFM	2708	2640	2565	2483	2396	2202	1967	1617		
		BHP	0.56	0.58	0.6	0.61	0.62	0.64	0.65	0.61		
		Sones	17.2	16.5	16.3	15.6	13.9	12.5	12.2	10.8		
	1550	CFM	2808	2743	2671	2594	2509	2329	2110	1823	1349	
		BHP	0.63	0.64	0.66	0.68	0.69	0.71	0.72	0.7	0.62	
		Sones	18.7	17.8	17.5	17.7	14.9	12.9	12.5	11.6	10.2	
	1595	CFM	2889	2826	2757	2683	2602	2430	2225	1968	1568	
		BHP	0.69	0.7	0.72	0.74	0.75	0.77	0.79	0.78	0.71	
		Sones	20.0	19.0	18.5	19.5	16.1	13.3	12.3	12.6	11.6	
1	1725	CFM	3124	3066	3005	2936	2865	2711	2539	2339	2085	1704
		BHP	0.87	0.88	0.9	0.92	0.94	0.97	0.99	1.00	0.98	0.91
		Sones	26.0	23.0	22.0	24.0	24.0	15.1	13.4	14.3	13.8	13.8

Voltage: 230V	Roof opening: 355(mm) diameter	IP:54 Class:F
Frequency: 60Hz	High Temperature: 257°F	Appx Weight: 39 KGS

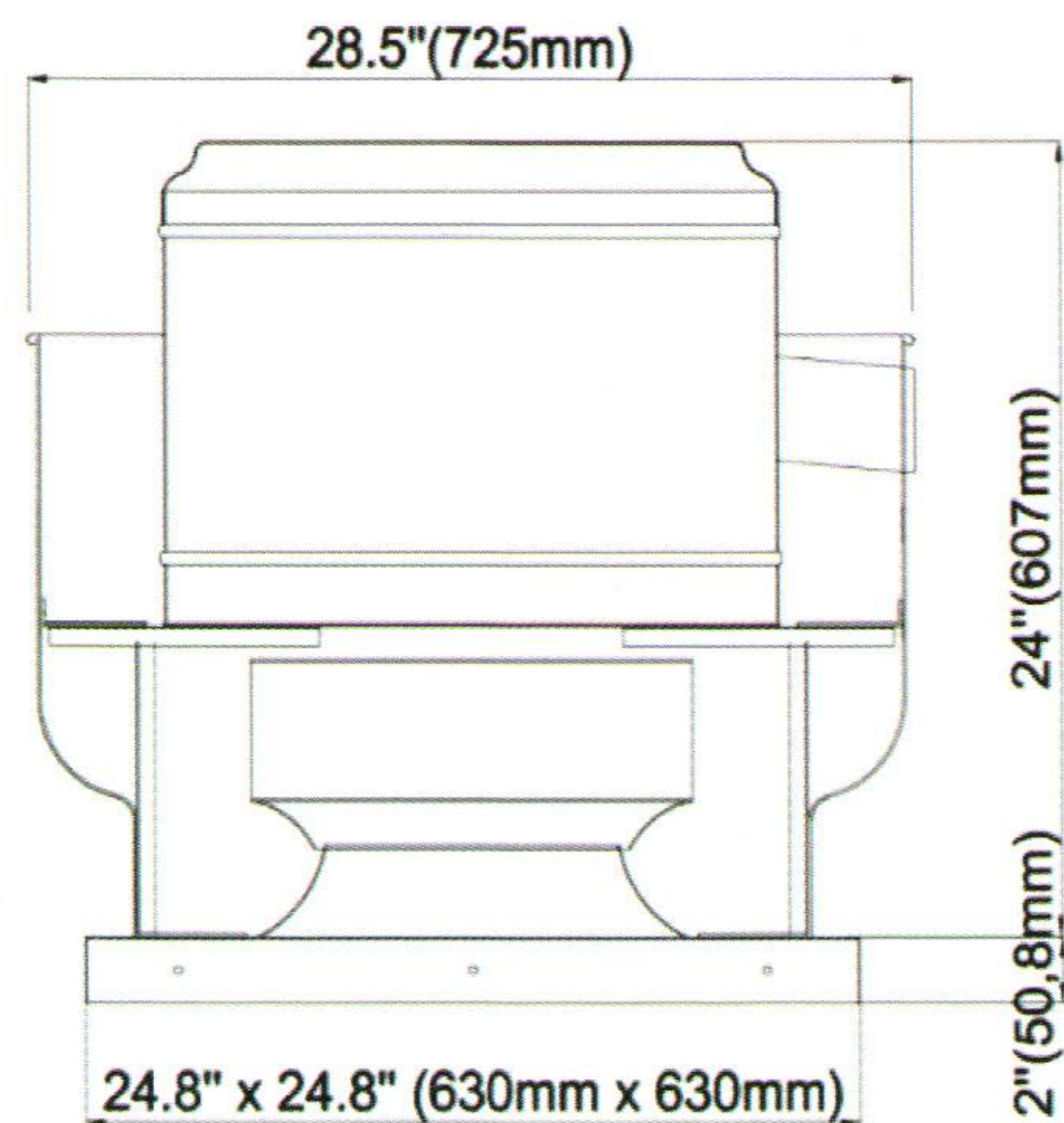
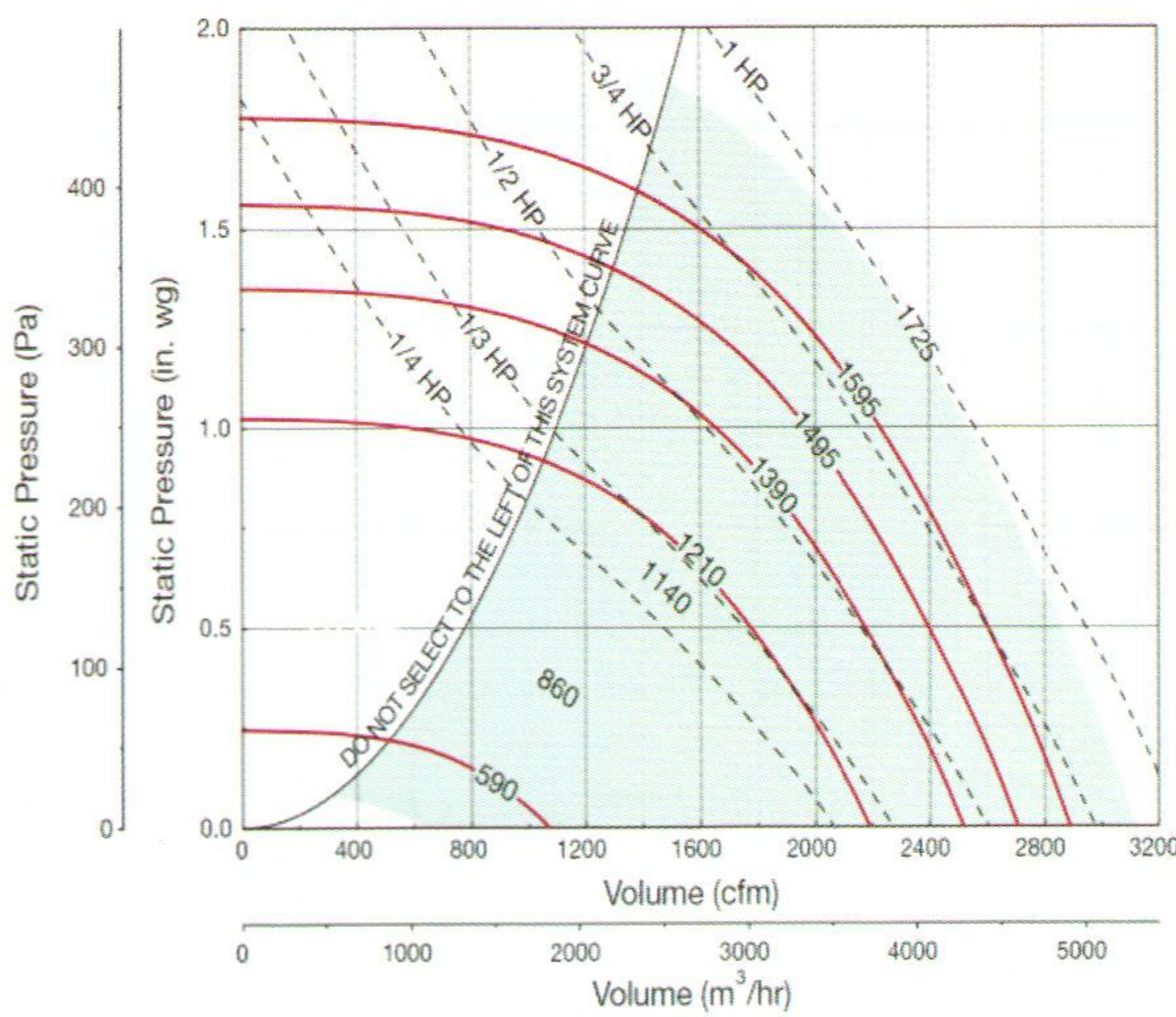



RUB UPBLAST  
ROOF EXHAUST FAN

Motor HP	Fan RPM	Static Pressure in Inches wg											
			0	0.125	0.25	0.375	0.5	0.625	0.75	0.875	1	1.5	
RUB-14BS-C													
1/4	730	CFM	2098	1905	1669	1389							
		BHP	0.13	0.15	0.15	0.15							
		Sones	8.1	8.0	7.8	7.8							
	805	CFM	2314	2143	1937	1708	1396						
		BHP	0.18	0.20	0.20	0.20	0.19						
		Sones	9.5	9.2	8.9	8.8	8.7						
	860	CFM	2472	2315	2126	1918	1680						
		BHP	0.22	0.24	0.25	0.25	0.24						
		Sones	10.7	10.2	9.9	9.7	9.5						
	875	CFM	2515	2362	2177	1974	1744	1365					
		BHP	0.23	0.26	0.26	0.26	0.26	0.24					
		Sones	11	10.6	10.1	9.9	9.7	9.7					
1/3	965	CFM	2774	2637	2477	2300	2109	1893	1584				
		BHP	0.31	0.34	0.35	0.35	0.35	0.34	0.33				
		Sones	12.4	12.0	11.5	11.2	10.8	10.6	10.6				
1/2	1110	CFM	3191	3072	2941	2796	2641	2475	2297	1770			
		BHP	0.47	0.51	0.53	0.53	0.54	0.53	0.52	0.49			
		Sones	15	14.6	14.2	13.8	13.5	13.1	12.9	12.5			
3/4	1140	CFM	3277	3161	3035	2896	2745	2587	2421	1983			
		BHP	0.51	0.55	0.57	0.57	0.58	0.58	0.57	0.55			
		Sones	15.7	15.2	14.8	14.4	14.1	13.8	13.5	13.2			
	1265	CFM	3636	3532	3426	3301	3172	3036	2894	2583	2163		
		BHP	0.70	0.74	0.77	0.78	0.79	0.79	0.79	0.78	0.75		
		Sones	18.5	18.1	17.6	17.2	16.8	16.5	16.3	15.8	15.6		
1	1300	CFM	3737	3636	3534	3413	3290	3157	3022	2729	2357		
		BHP	0.76	0.80	0.84	0.85	0.85	0.86	0.86	0.84	0.82		
		Sones	19.1	18.7	18.3	17.9	17.5	17.2	17	16.5	16.3		
	1390	CFM	3996	3901	3806	3698	3584	3464	3340	3078	2785	2394	
		BHP	0.93	0.97	1.01	1.03	1.04	1.04	1.05	1.04	1.03	1.00	
		Sones	21.0	21.0	20.0	19.7	19.3	19.0	18.8	18.4	18.0	17.9	
2	1725	CFM	4959	4882	4806	4729	4646	4554	4463	4269	4070	3855	
		BHP	1.77	1.83	1.88	1.94	1.97	1.97	1.98	2.00	2.01	1.99	
		Sones	30.0	29.0	29.0	29.0	28.0	28.0	27.0	27.0	27.0	26.0	

Voltage: 230V	Roof opening: 400(mm) diameter	IP:54 Class:F
Frequency: 60Hz	High Temperature: 257°F	Appx Weight: 49 KGS

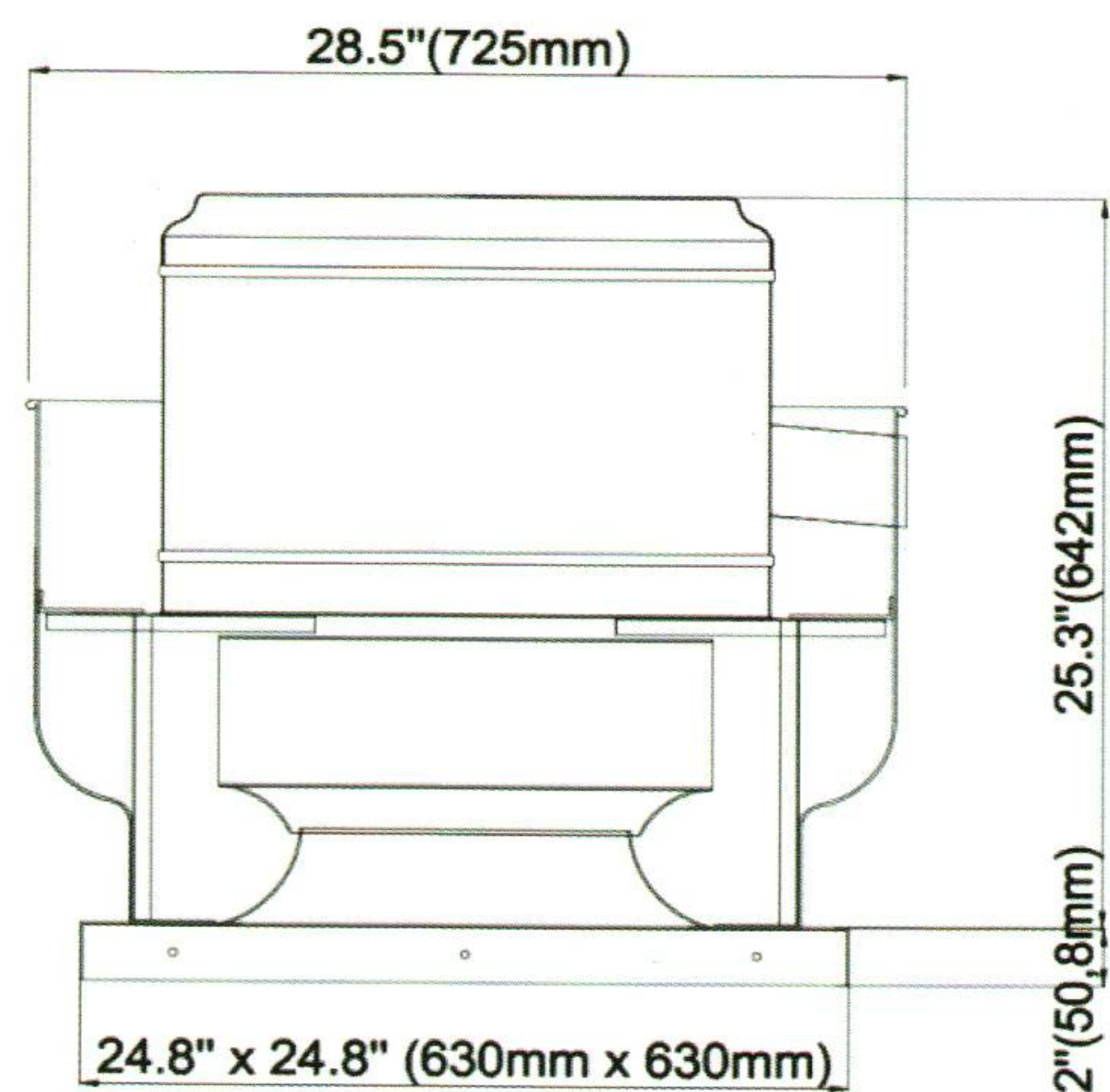
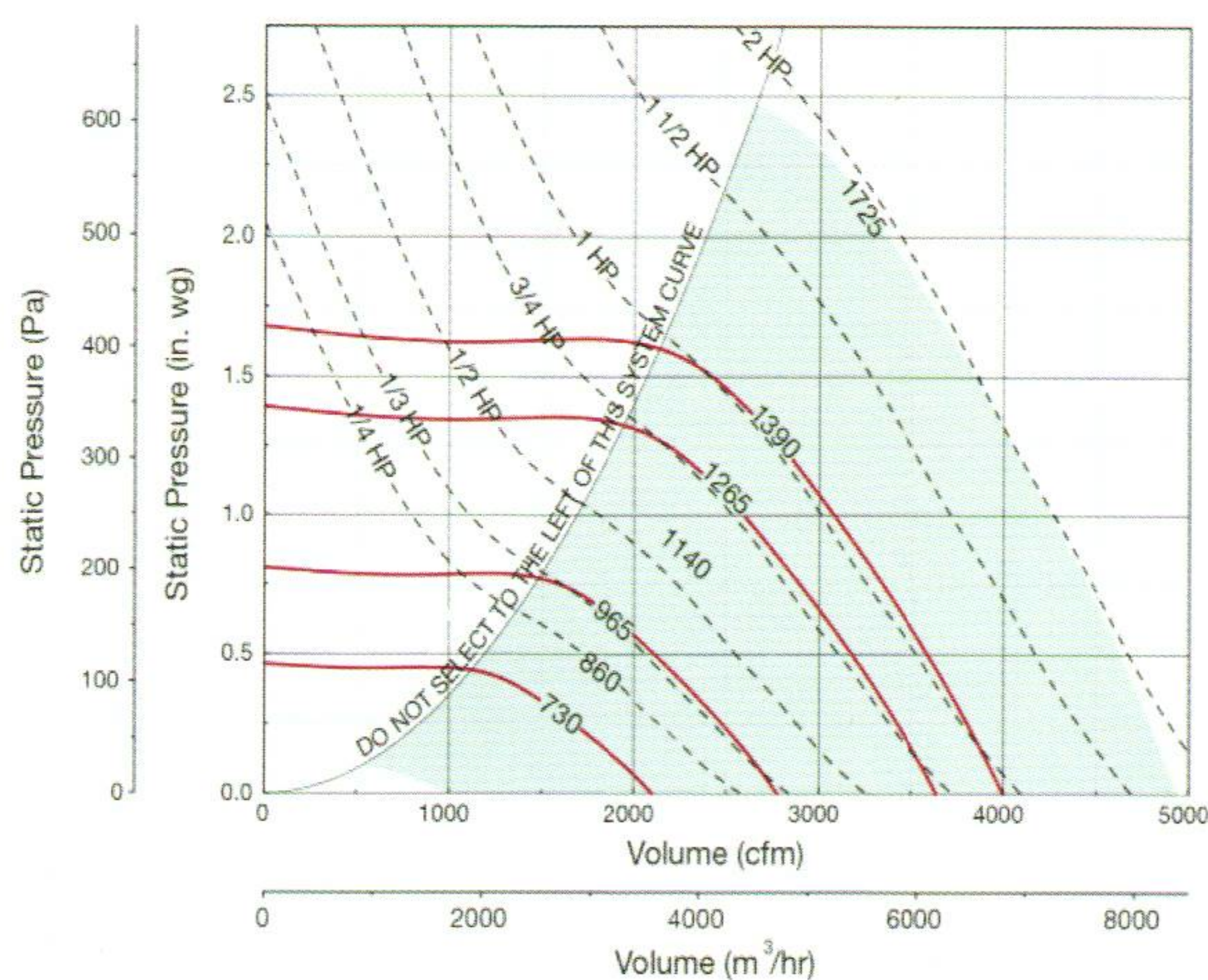



RUB UPBLAST  
ROOF EXHAUST FAN

Motor HP Belt	Fan RPM		Static Pressure in Inches wg									
			0	0.125	0.25	0.5	0.75	1	1.25	1.5	1.75	2
RUB-16BS-C												
1/4	745	CFM	2815	2617	2448	1763						
		BHP	0.22	0.24	0.26	0.25						
		Sones	9.2	8.6	8.1	7.1						
1/3	820	CFM	3098	2916	2759	2257						
		BHP	0.30	0.32	0.34	0.34						
		Sones	11.2	10.4	10.0	9.0						
1/2	860	CFM	3249	3074	2922	2474						
		BHP	0.34	0.37	0.39	0.40						
		Sones	12.3	11.7	11.1	10.2						
	940	CFM	3551	3389	3243	2879	2363					
		BHP	0.45	0.47	0.49	0.52	0.50					
		Sones	13.8	13.5	13.1	12.4	11.2					
3/4	1000	CFM	3778	3625	3486	3190	2738					
		BHP	0.54	0.57	0.59	0.63	0.62					
		Sones	15.1	14.9	14.7	14.3	13.3					
	1075	CFM	4061	3919	3786	3554	3141	2652				
		BHP	0.67	0.70	0.73	0.78	0.78	0.75				
		Sones	16.5	16.2	15.8	15.5	14.7	13.3				
1	1140	CFM	4307	4173	4045	3822	3470	3072	2477			
		BHP	0.80	0.83	0.86	0.91	0.93	0.92	0.85			
		Sones	17.6	17.1	16.5	16.1	15.4	14.6	13.6			
	1185	CFM	4477	4348	4224	4005	3703	3336	2841			
		BHP	0.90	0.93	0.96	1.01	1.04	1.04	0.99			
		Sones	18.5	17.9	17.1	16.5	16	15.2	14.4			
1 1/2	1275	CFM	4817	4697	4578	4369	4163	3799	3437	2930		
		BHP	1.12	1.15	1.19	1.24	1.30	1.30	1.28	1.22		
		Sones	21.0	20.0	19.5	18.7	18.2	17.5	16.7	15.9		
	1360	CFM	5138	5026	4913	4710	4532	4232	3912	3537	3023	
		BHP	1.36	1.39	1.43	1.47	1.56	1.58	1.58	1.54	1.46	
		Sones	23.0	23.0	22.0	21.0	21.0	20.0	19.2	18.3	17.3	
2	1495	CFM	5648	5546	5443	5254	5082	4921	4598	4313	3983	3564
		BHP	1.80	1.84	1.89	1.96	2.02	2.10	2.10	2.10	2.06	1.99
		Sones	28.0	27.0	27.0	26.0	25.0	25.0	24.0	23.0	22.0	21.0

Voltage: 230V	Roof opening: 450 (mm) diameter	IP:54 Class:F
Frequency: 60Hz	High Temperature: 257°F	Appx Weight: 63 KGS

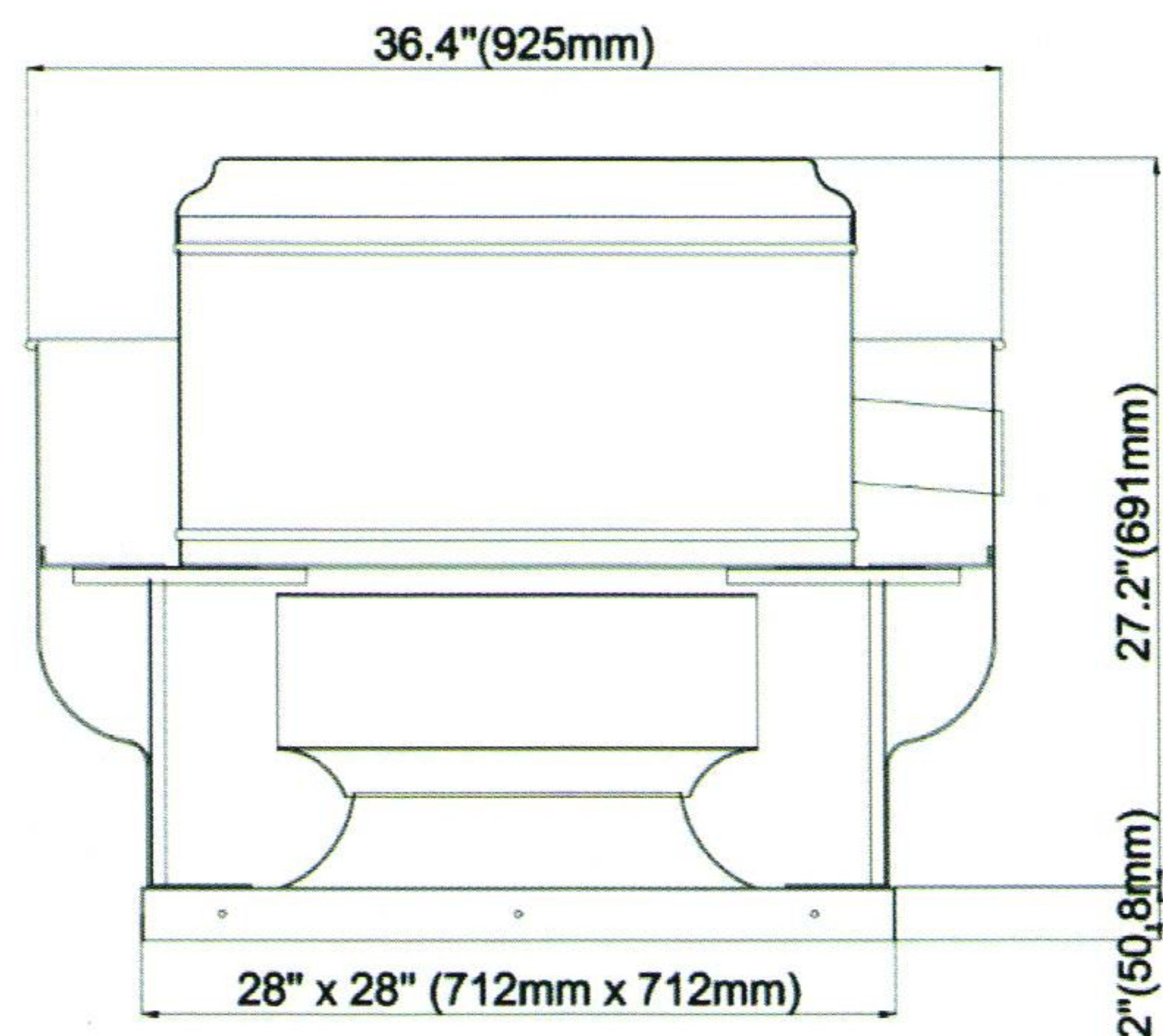
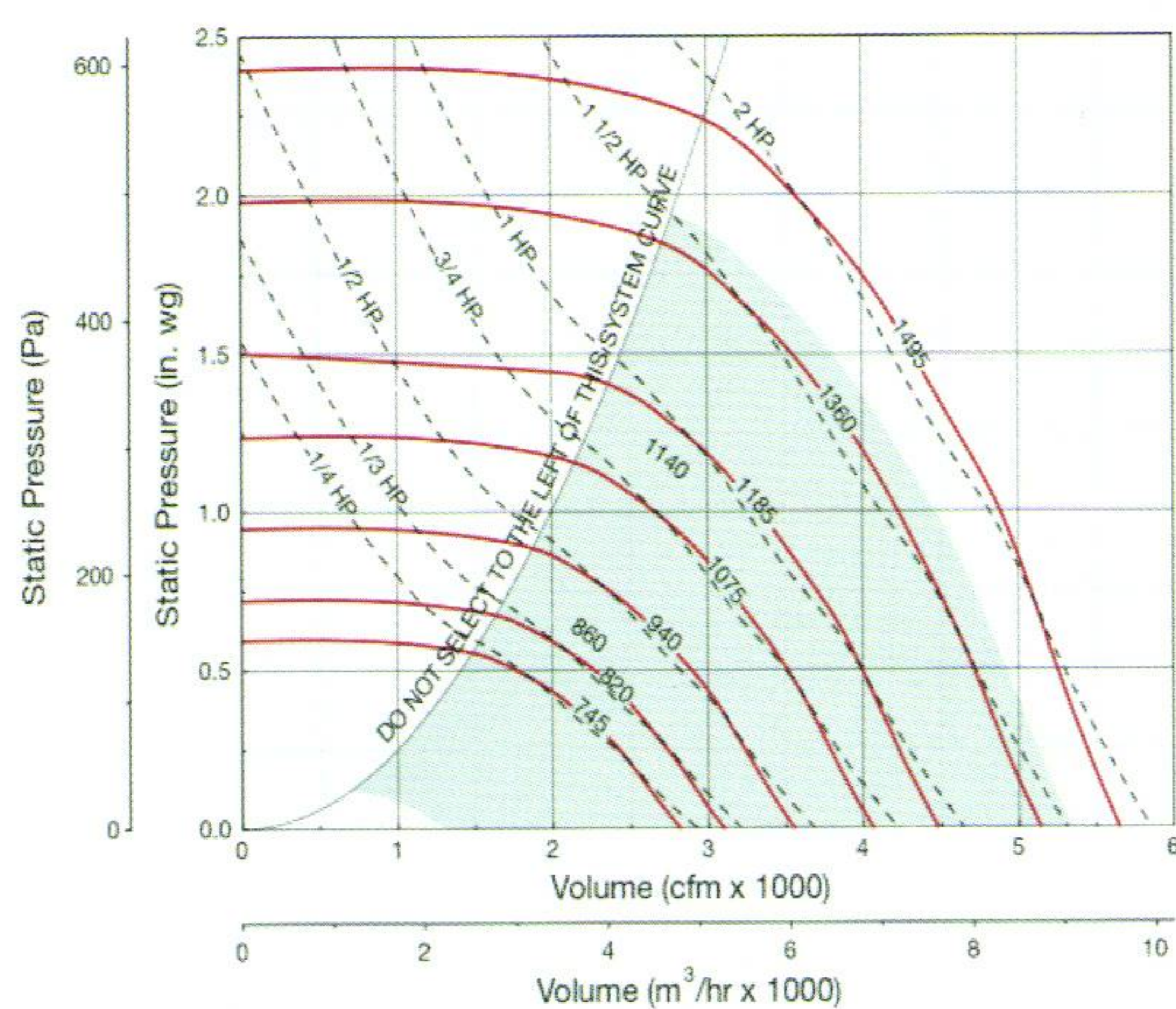



RUB UPBLAST  
ROOF EXHAUST FAN

Motor HP Belt	Fan RPM	Static Pressure in Inches wg										
			0	0.125	0.25	0.375	0.5	0.75	1	1.25	1.5	1.75
RUB-18BS-C												
1/4	605	CFM	3403	3054	2675	2144						
		BHP	0.25	0.26	0.26	0.25						
		Sones	8.2	7.6	6.8	6.2						
1/3	665	CFM	3740	3422	3096	2699	2073					
		BHP	0.33	0.34	0.35	0.35	0.33					
		Sones	9.6	9.0	8.3	7.5	7.2					
1/2	760	CFM	4275	3994	3718	3413	3048					
		BHP	0.49	0.51	0.52	0.52	0.51					
		Sones	12.3	11.8	11.1	10.2	9.5					
3/4	820	CFM	4612	4350	4098	3828	3523	2606				
		BHP	0.61	0.63	0.65	0.65	0.65	0.61				
		Sones	14.2	14.1	13.3	12.5	11.5	10.9				
	860	CFM	4837	4587	4346	4093	3815	3084				
		BHP	0.71	0.73	0.74	0.75	0.75	0.73				
		Sones	15.8	15.7	14.9	14.4	13	12				
	875	CFM	4922	4676	4439	4192	3922	3240				
		BHP	0.75	0.77	0.78	0.79	0.79	0.78				
		Sones	16.4	16.4	15.6	15.1	13.7	12.6				
1	960	CFM	5400	5176	4958	4742	4508	3985	3169			
		BHP	0.98	1.01	1.03	1.04	1.04	1.04	1.00			
		Sones	18.9	18.6	18.0	17.4	16.7	15.2	14.7			
1 1/2	1030	CFM	5793	5585	5380	5179	4968	4503	3917	2972		
		BHP	1.22	1.24	1.26	1.28	1.29	1.29	1.27	1.18		
		Sones	21	21	20	19.7	19.2	17.8	16.6	17.1		
	1100	CFM	6187	5992	5798	5610	5421	5006	4529	3861		
		BHP	1.48	1.51	1.53	1.55	1.57	1.57	1.57	1.53		
		Sones	24	23	23	22	22	21	19.7	18.9		
2	1140	CFM	6412	6224	6036	5855	5674	5283	4837	4276	3445	
		BHP	1.65	1.67	1.7	1.72	1.74	1.74	1.74	1.73	1.63	
		Sones	25	24	24	23	22	22	21	19.6	20	
	1210	CFM	6806	6628	6451	6279	6108	5748	5350	4892	4289	3365
		BHP	1.97	2	2.03	2.05	2.07	2.09	2.09	2.08	2.04	1.88
		Sones	24	24	23	23	23	22	21	20	20	21

Voltage: 230V	Roof opening: 500 (mm) diameter	IP:54 Class:F
Frequency: 60Hz	High Temperature: 257°F	Appx Weight: 76 KGS

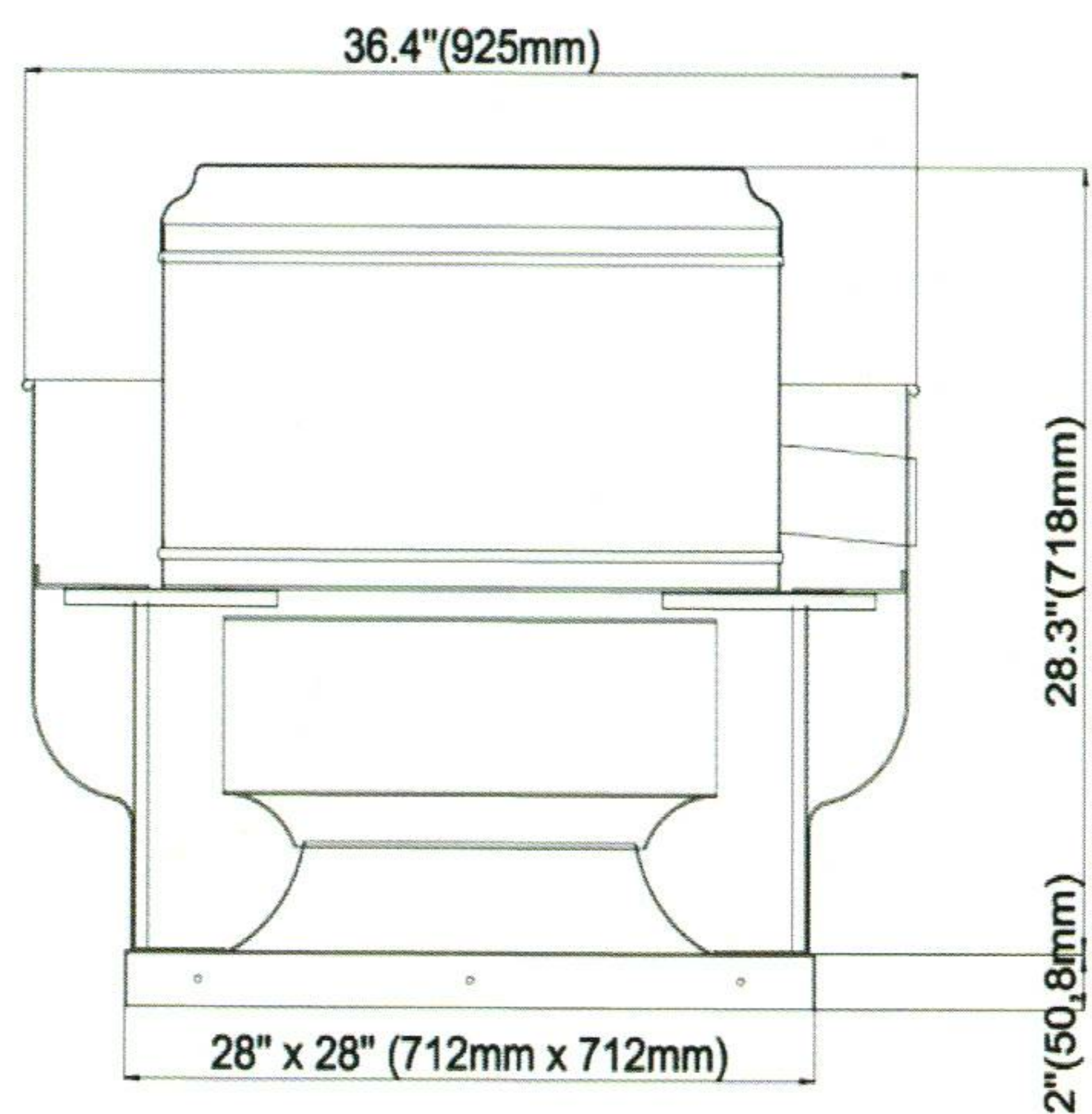
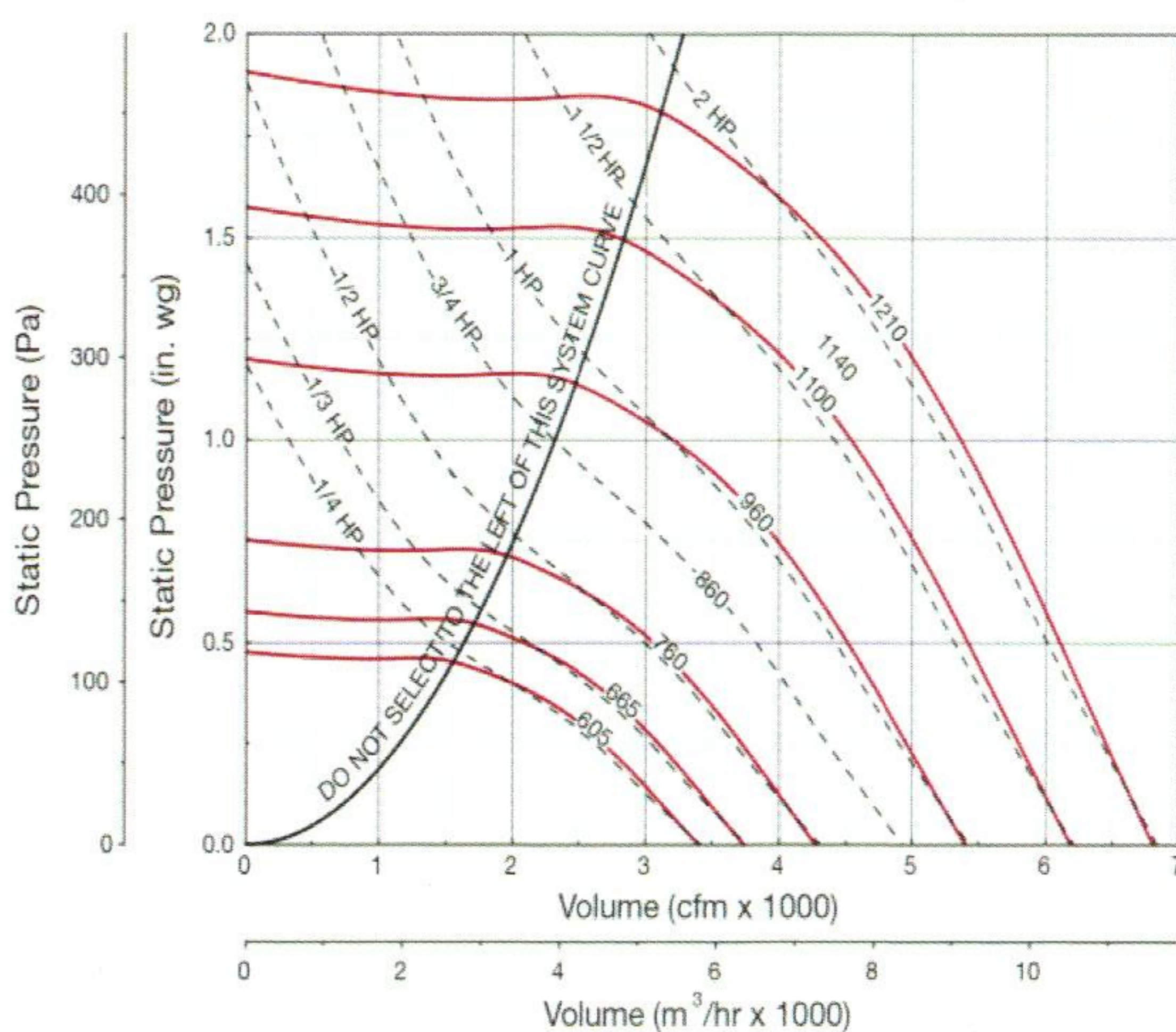



RUB UPBLAST  
ROOF EXHAUST FAN

Motor HP	Fan RPM	Static Pressure in Inches wg										
		0	0.125	0.25	0.375	0.5	0.625	0.75	1	1.25	1.5	
RUB-20BS-C												
1/4	450	CFM	3585	3155	2624							
		BHP	0.19	0.21	0.22							
		Sones	7.4	6.8	6.2							
1/4	475	CFM	3784	3377	2896	2268						
		BHP	0.23	0.25	0.26	0.25						
		Sones	8	7.3	6.7	6.2						
1/3	520	CFM	4142	3771	3357	2845						
		BHP	0.3	0.32	0.34	0.34						
		Sones	9.3	8.5	7.7	7.2						
1/2	600	CFM	4779	4457	4124	3736	3279					
		BHP	0.46	0.48	0.51	0.52	0.52					
		Sones	12	11.1	10.2	9.5	8.9					
3/4	645	CFM	5138	4838	4539	4194	3811	3346				
		BHP	0.57	0.6	0.63	0.64	0.65	0.64				
		Sones	13.6	12.7	12	11.3	10.6	10				
3/4	685	CFM	5457	5174	4893	4581	4234	3836	3383			
		BHP	0.68	0.71	0.74	0.76	0.78	0.78	0.77			
		Sones	15	14.2	13.7	13.2	12.3	11.7	11.2			
1	755	CFM	6014	5758	5502	5239	4944	4620	4258			
		BHP	0.91	0.94	0.98	1.01	1.03	1.04	1.04			
		Sones	17.7	17	16.6	16.3	15.8	14.9	14.4			
1 1/2	810	CFM	6452	6213	5975	5737	5470	5185	4883	4156		
		BHP	1.13	1.16	1.2	1.24	1.26	1.28	1.29	1.27		
		Sones	19	18.5	17.9	17.6	17.2	16.5	15.7	14.8		
1 1/2	865	CFM	6890	6667	6443	6220	5987	5729	5453	4835	4111	
		BHP	1.37	1.41	1.45	1.49	1.52	1.54	1.56	1.57	1.53	
		Sones	21	20	19.6	19.2	18.7	18.1	17.4	16.5	16.1	
2	910	CFM	7249	7036	6823	6612	6400	6158	5909	5365	4704	
		BHP	1.6	1.64	1.68	1.72	1.76	1.78	1.81	1.83	1.81	
		Sones	23	22	22	21	21	20	19.3	18.3	17.4	
2	955	CFM	7607	7405	7202	7000	6799	6580	6347	5844	5261	4602
		BHP	1.85	1.89	1.93	1.97	2.02	2.05	2.07	2.11	2.11	2.07
		Sones	25	25	24	24	23	23	22	20	19.4	18.9

Voltage: 230V	Roof opening: 560 (mm) diameter	IP:54 Class:F
Frequency: 60Hz	High Temperature: 257°F	Appx Weight: 107 KGS

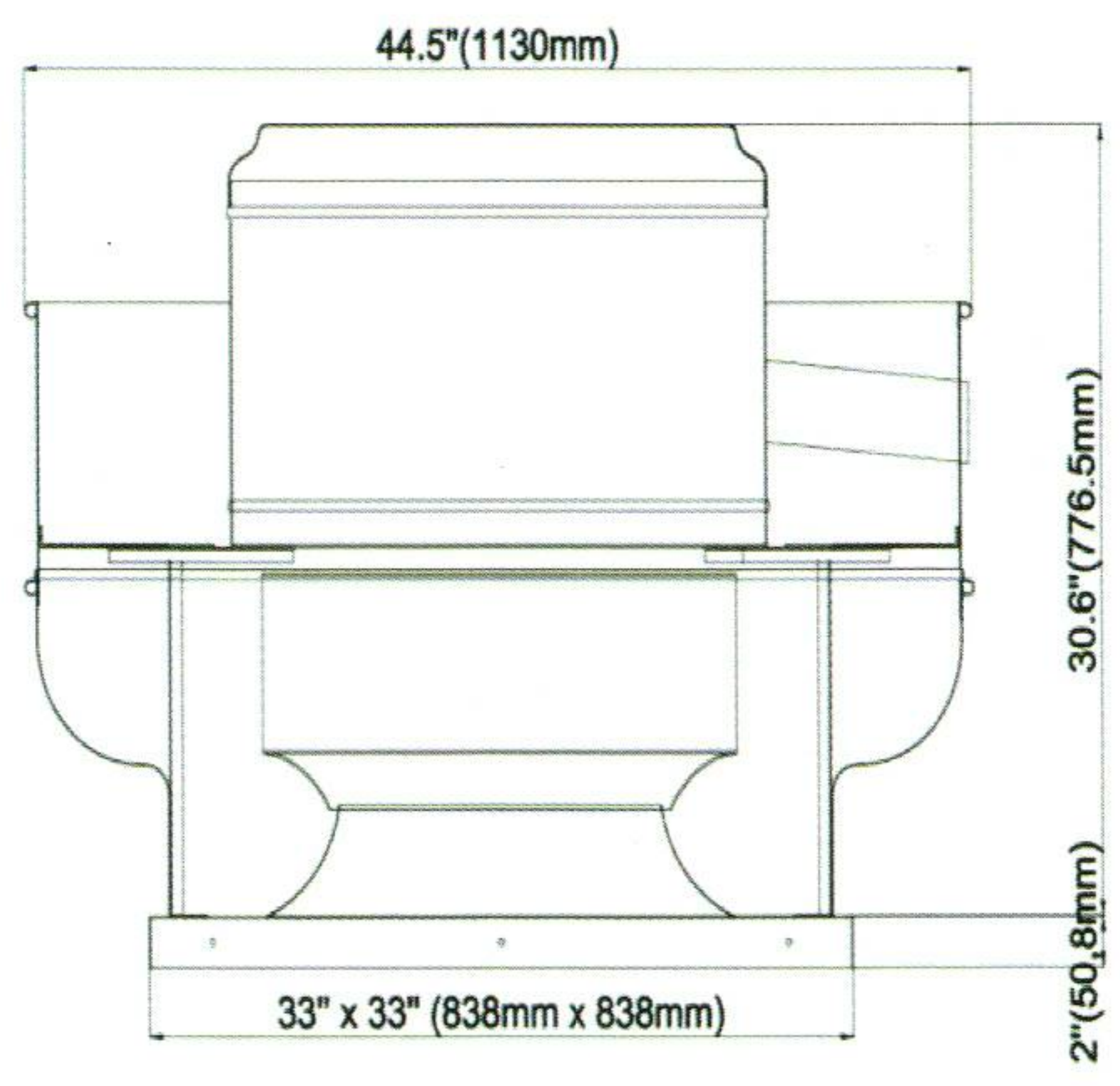
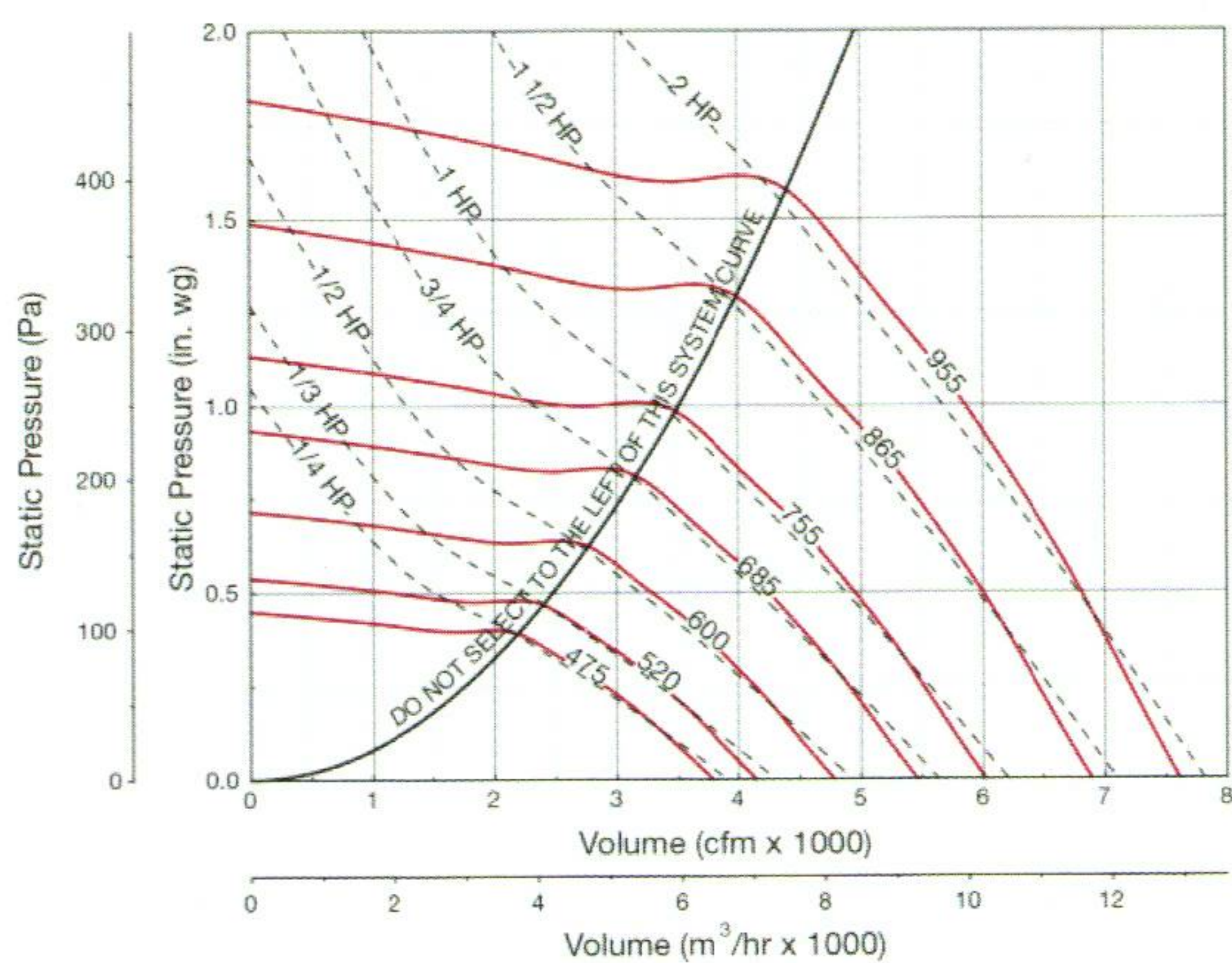



RUB UPBLAST  
ROOF EXHAUST FAN

Motor HP	Fan RPM	Static Pressure in Inches wg										
		0	0.125	0.25	0.375	0.5	0.625	0.75	1	1.25	1.5	
RUB-24BS-C												
1/4	410	CFM	3717	3170	2471							
		BHP	0.16	0.18	0.18							
		Sones	6.4	5.8	5.3							
	465	CFM	4216	3768	3188	2162						
		BHP	0.23	0.25	0.26	0.23						
		Sones	7.6	7.0	6.3	5.9						
1/3	510	CFM	4623	4243	3717	3134						
		BHP	0.31	0.33	0.34	0.34						
		Sones	8.9	8.1	7.3	6.9						
1/2	585	CFM	5303	4961	4540	4093	3565					
		BHP	0.46	0.49	0.51	0.52	0.51					
		Sones	11.5	10.5	9.5	8.8	8.4					
3/4	628	CFM	5693	5368	5010	4590	4141	3600				
		BHP	0.57	0.61	0.63	0.64	0.65	0.63				
		Sones	12.9	11.9	11.1	10.4	9.8	9.4				
	670	CFM	6074	5763	5461	5052	4659	4202	3524			
		BHP	0.69	0.74	0.76	0.78	0.79	0.78	0.73			
		Sones	14.3	13.4	12.8	12.2	11.5	11.0	10.6			
1	735	CFM	6663	6370	6133	5764	5409	5037	4618			
		BHP	0.92	0.97	0.99	1.01	1.03	1.04	1.03			
		Sones	16.6	15.9	15.5	15.1	14.6	13.9	13.4			
1 1/2	790	CFM	7162	6883	6661	6361	6011	5693	5332	4453		
		BHP	1.14	1.2	1.22	1.25	1.27	1.28	1.29	1.24		
		Sones	18.2	17.5	17.2	16.8	16.3	15.7	15	14.3		
	845	CFM	7660	7400	7184	6947	6615	6304	6002	5282		
		BHP	1.39	1.46	1.49	1.51	1.54	1.56	1.57	1.65		
		Sones	19.6	19.0	18.6	18.2	17.6	17.0	16.4	15.4		
2	888	CFM	8050	7802	7590	7394	7083	6772	6489	5854	5008	
		BHP	1.62	1.69	1.72	1.75	1.78	1.81	1.82	1.83	1.77	
		Sones	21	21	21	20	19.5	18.7	18.0	17.0	16.4	
	930	CFM	8431	8194	7985	7798	7536	7233	6953	6375	5706	4324
		BHP	1.86	1.93	1.98	2.00	2.03	2.06	2.08	2.1	2.07	1.83
		Sones	24	23	23	22	22	21	19.9	18.7	17.8	17.9

Voltage: 230V	Roof opening: 630 (mm) diameter	IP:54 Class:F
Frequency: 60Hz	High Temperature: 257°F	Appx Weight: 107 KGS

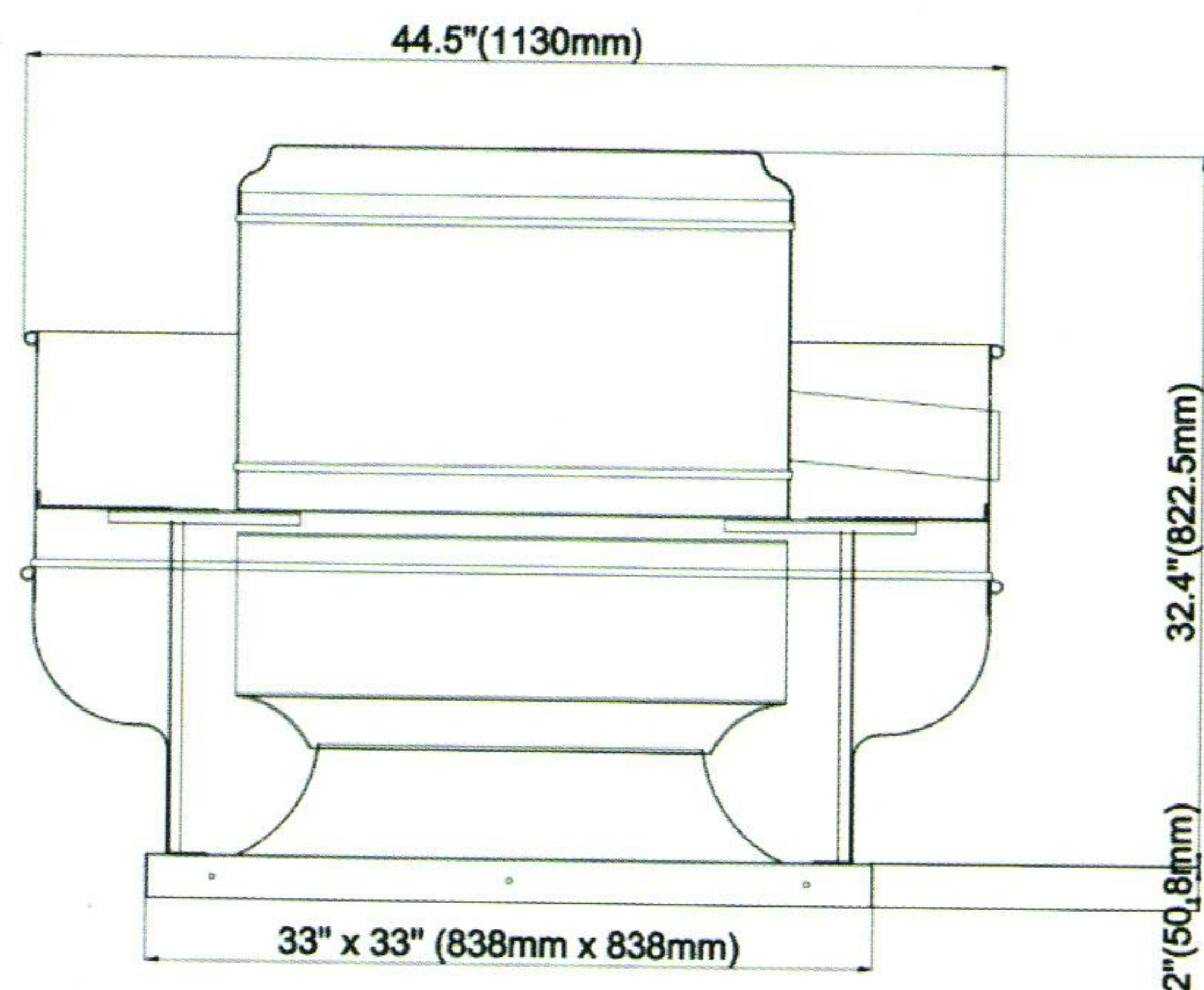
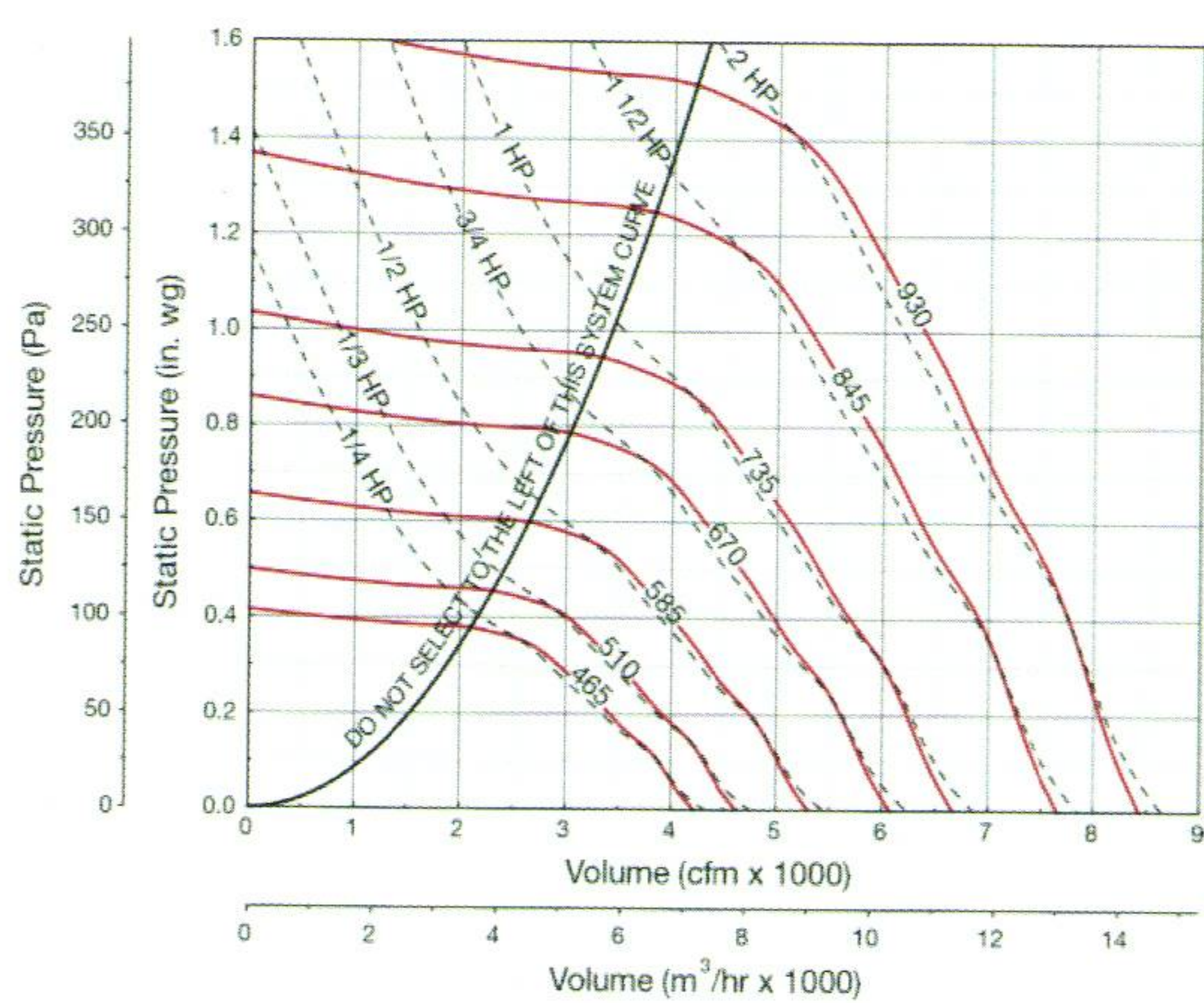



RUB UPBLAST  
ROOF EXHAUST FAN

Motor HP	Fan RPM	Static Pressure in Inches wg										
		0	0.125	0.25	0.375	0.5	0.625	0.75	1	1.25	1.5	
RUB-24BS-C												
1/4	410	CFM	3717	3170	2471							
		BHP	0.16	0.18	0.18							
		Sones	6.4	5.8	5.3							
	465	CFM	4216	3768	3188	2162						
		BHP	0.23	0.25	0.26	0.23						
		Sones	7.6	7.0	6.3	5.9						
1/3	510	CFM	4623	4243	3717	3134						
		BHP	0.31	0.33	0.34	0.34						
		Sones	8.9	8.1	7.3	6.9						
1/2	585	CFM	5303	4961	4540	4093	3565					
		BHP	0.46	0.49	0.51	0.52	0.51					
		Sones	11.5	10.5	9.5	8.8	8.4					
3/4	628	CFM	5693	5368	5010	4590	4141	3600				
		BHP	0.57	0.61	0.63	0.64	0.65	0.63				
		Sones	12.9	11.9	11.1	10.4	9.8	9.4				
	670	CFM	6074	5763	5461	5052	4659	4202	3524			
		BHP	0.69	0.74	0.76	0.78	0.79	0.78	0.73			
		Sones	14.3	13.4	12.8	12.2	11.5	11.0	10.6			
1	735	CFM	6663	6370	6133	5764	5409	5037	4618			
		BHP	0.92	0.97	0.99	1.01	1.03	1.04	1.03			
		Sones	16.6	15.9	15.5	15.1	14.6	13.9	13.4			
1 1/2	790	CFM	7162	6883	6661	6361	6011	5693	5332	4453		
		BHP	1.14	1.2	1.22	1.25	1.27	1.28	1.29	1.24		
		Sones	18.2	17.5	17.2	16.8	16.3	15.7	15	14.3		
	845	CFM	7660	7400	7184	6947	6615	6304	6002	5282		
		BHP	1.39	1.46	1.49	1.51	1.54	1.56	1.57	1.65		
		Sones	19.6	19.0	18.6	18.2	17.6	17.0	16.4	15.4		
2	888	CFM	8050	7802	7590	7394	7083	6772	6489	5854	5008	
		BHP	1.62	1.69	1.72	1.75	1.78	1.81	1.82	1.83	1.77	
		Sones	21	21	21	20	19.5	18.7	18.0	17.0	16.4	
	930	CFM	8431	8194	7985	7798	7536	7233	6953	6375	5706	4324
		BHP	1.86	1.93	1.98	2.00	2.03	2.06	2.08	2.1	2.07	1.83
		Sones	24	23	23	22	22	21	19.9	18.7	17.8	17.9

Voltage: 380V	Roof opening: 630 (mm) diameter	IP:54 Class:F
Frequency: 60Hz	High Temperature: 257°F	Appx Weight: 107 KGS

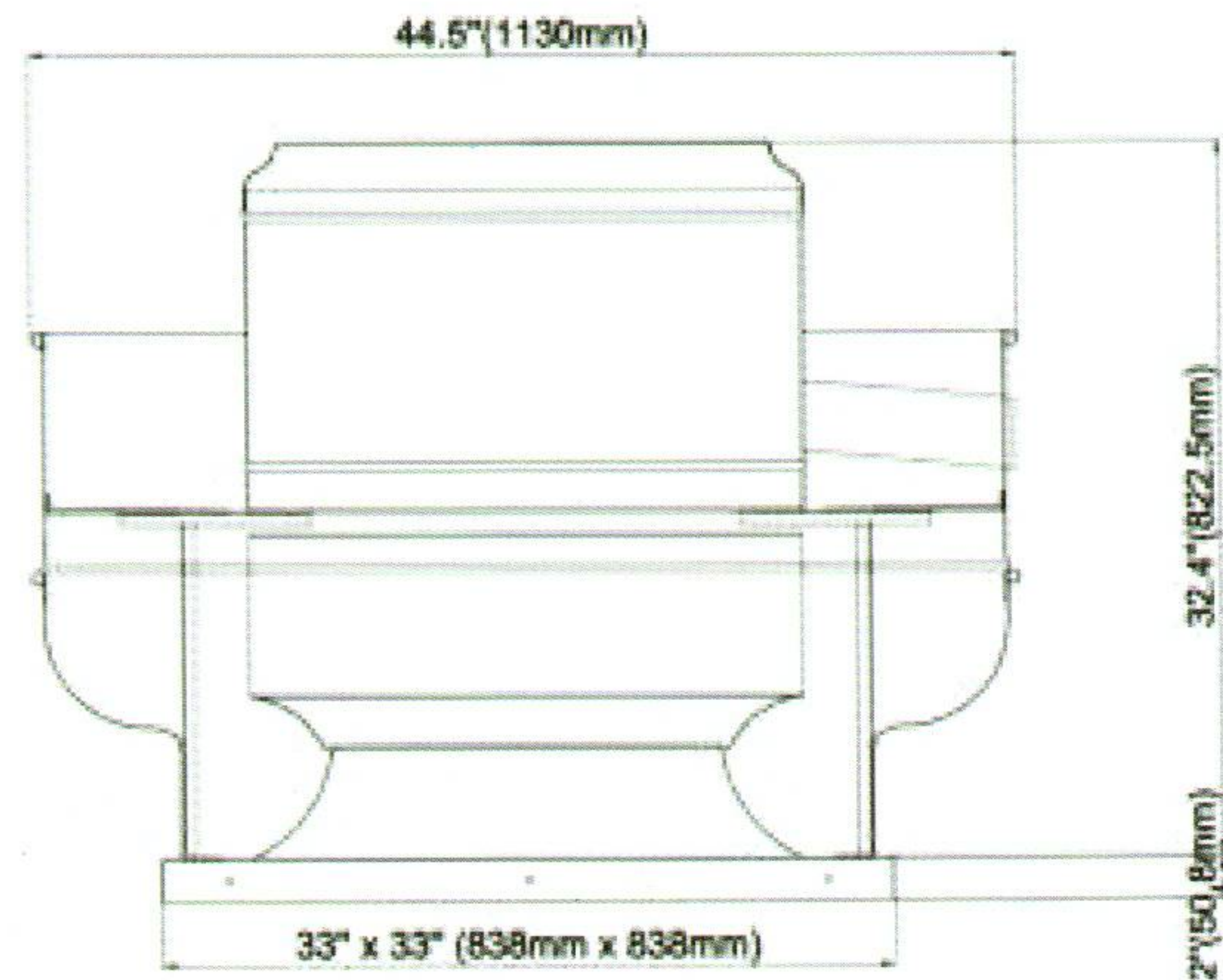
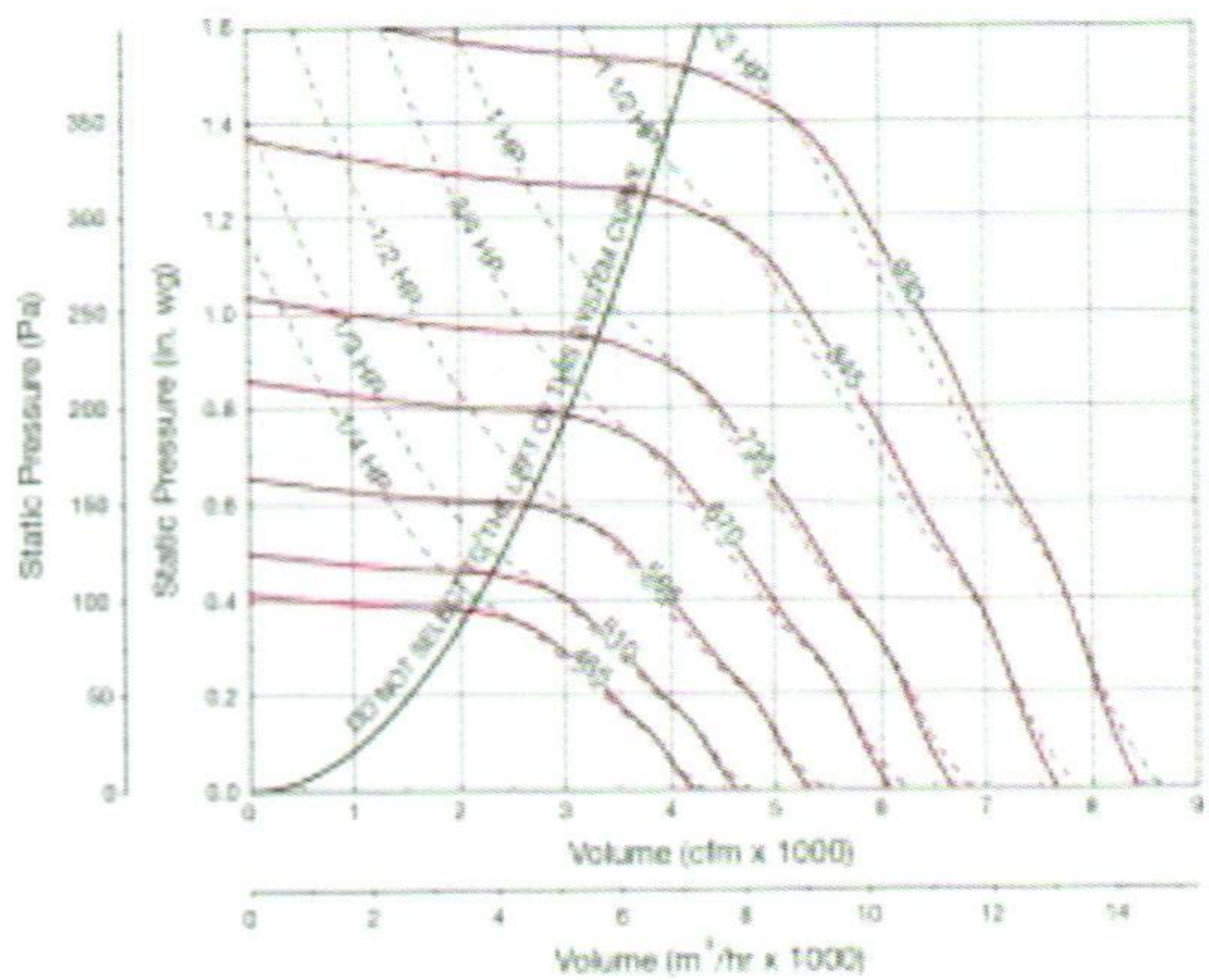





*High volume exhausting*

